

## AS5221 Ultra Low Jitter Low Power Differential TCXO

### Description

The AS5221 is a temperature compensated crystal oscillator (TCXO) with a pair of low-amplitude LVCMOS output clock between 10 MHz and 156.25 MHz. The AS5221 utilizes digital temperature sensing and frequency compensation technologies to provide a high precision, temperature stabilized clock with grade options from  $\pm 5\text{ppm}$  to  $\pm 20\text{ppm}$ .

The AS5221 operates in a wide power supply range from 1.5V to 3.3V. The on-chip LDOs ensure robust power supply noise rejection which simplifies the external supply noise filtering requirements.

The AS5221 supports configurable output amplitude from 0.8V to 1.2V. The 0.8V output option is compliant with clipped sine (0.8V CS) which is widely adopted in the industry. The two outputs can be configured as in-phase or complementary. When it's configured as complementary, the outputs can be used as a differential pair.

Available in industry-standard 2016 package, the AS5221 comes in industrial, extended industrial and automotive device grades. Specific combination of package, frequency, stability, driver format, and device grade can be selected at the time of ordering.

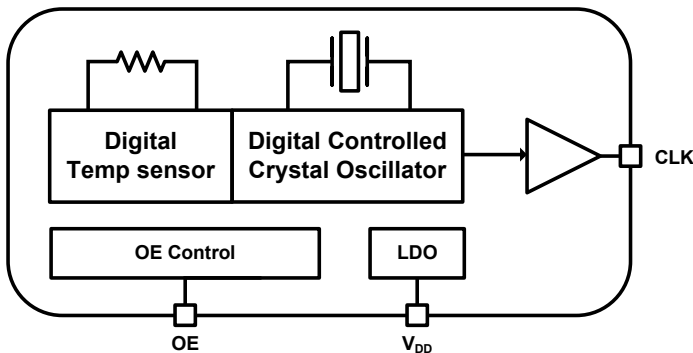

### Key Features

- Frequency range: 10 to 156.25 MHz
- Dual LVCMOS and Differential output options
- 0.8, 1.0, 1.2V output amplitude/swing options
- Ultra-low jitter: 52 fs Typ (12 kHz – 20 MHz, @156.25 MHz)
- Ultra-low core power: 5mA
- Operating temperature range:
  - -40 to 85 °C (Industrial grade)
  - -40 to 105 °C (Extended-Industrial grade)
  - -40 to 105 °C (AEC-Q100 grade 2)
- Temperature stability:
  - $\pm 5$  ppm (Grade S)
  - $\pm 20$  ppm (Grade D)
- Integrated LDO for on-chip power supply noise filtering
- 1.5V to 3.3V  $V_{DD}$  supply operation
- Standard DFN 2016 package

### Application

- Microwave backhaul
- Communication networks
- Data center interconnect
- AI server clusters
- Smart network interface card
- High-speed optical module

### Pin definition

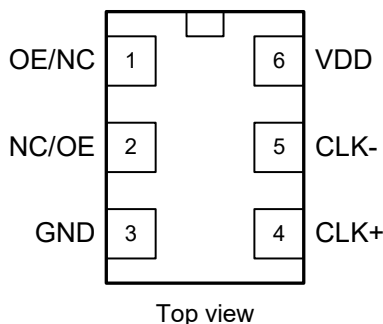

Pin#	Description
1,2	OE = Output enable. Active high NC = Not connect
3	GND = Ground
4	CLK+ = Clock output
5	CLK- = Complementary clock output
6	VDD = Power supply

## 1. Ordering Guide

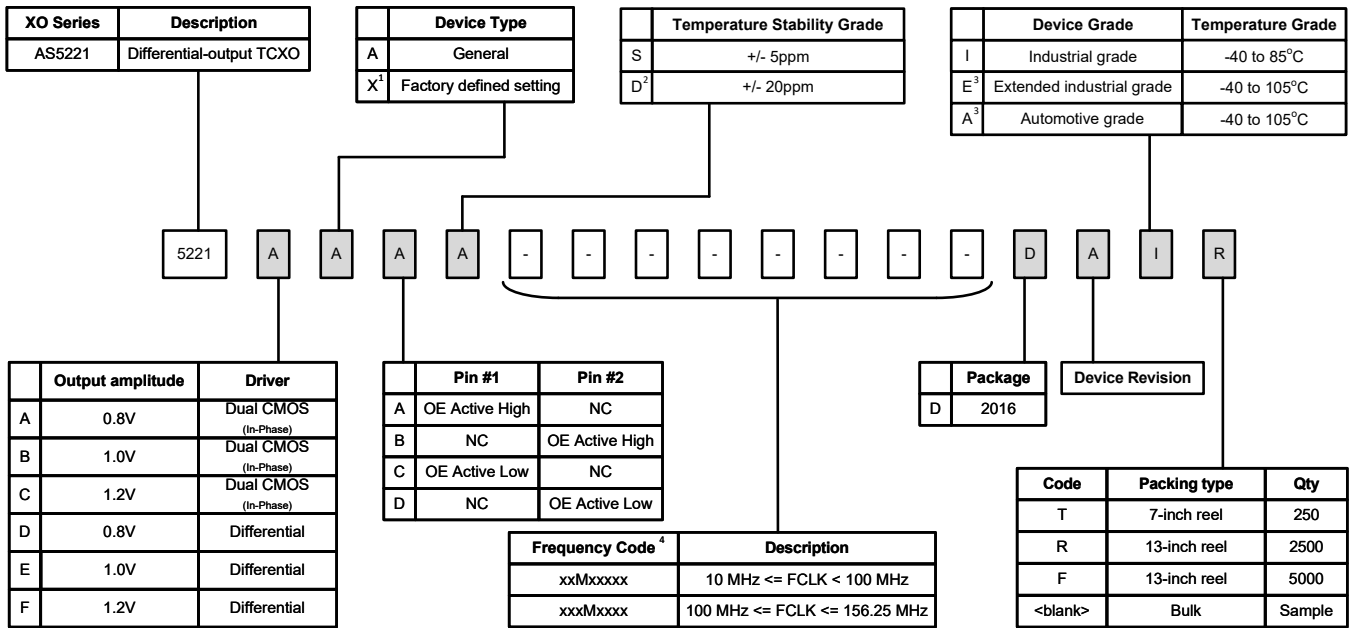

### Note:

1. "X" refers to the ID for the unique configuration with factory-defined settings, the value ranges from "B" to "Z".
2. Temperature compensation is not applied for grade-D device. Frequency is calibrated at 25 °C in production test.
3. Contact Aeonsemi for "Extended industrial" and "Automotive" grade device.
4. For example: 38.4 MHz = 38M40000; 156.25 MHz = 156M2500.

## 2. Electrical Specifications

**Table 2.1. Electrical Specifications**

Parameter	Symbol	Min	Typ	Max	Unit	Note
Operating Temperature Range						
Temperature Range	T <sub>A</sub>	-40	—	85	°C	Industrial grade
		-40	—	105	°C	Extended industrial grade
		-40	—	105	°C	Automotive AEC-Q100 Grade2
Supply Voltage and Power Consumption						
Supply Voltage	V <sub>DD</sub>	1.425	—	3.63	V	Core voltage
Driver Regulator Voltage	V <sub>R</sub>	0.8	—	1.2	V	Regulator voltage
Supply Current (F <sub>CLK</sub> = 156.25 MHz)	I <sub>CORE</sub>	—	4	5	mA	Tristate Hi-Z (Output disabled)
	I <sub>DRV</sub>	—	1.6	2	mA	0.8V LVCMOS (Load = 10pF // 10kΩ)
		—	2	2.5	mA	1.0V LVCMOS (Load = 10pF // 10kΩ)
		—	2.4	3	mA	1.2V LVCMOS (Load = 10pF // 10kΩ)
		—	6	7	mA	0.8V Differential (100 Ω termination)
		—	7.5	9	mA	1.0V Differential (100 Ω termination)
		—	9	11	mA	1.2V Differential (100 Ω termination)
Frequency Range						
Frequency Range	F <sub>CLK</sub>	10	—	156.25	MHz	Standard frequency options Contact Aeonsemi for other frequency options
		10, 16, 19.2, 20, 25, 26, 32, 38.4, 50, 52, 100, 155.52, 156.25				
Frequency Tolerance						
Initial frequency accuracy <sup>1</sup>	F <sub>INIT</sub>	-2	—	2	ppm	Grade S
		-5	—	5	ppm	Grade D
Temperature stability over full temp range <sup>2</sup>	F <sub>STAB</sub>	-5	—	5	ppm	Grade S
		-20	—	20	ppm	Grade D
Aging	S <sub>AGING</sub>	-1	—	1	ppm/y	Maximum aging slope at 25 °C
	F <sub>AGING</sub>	-3	—	3	ppm	10-year aging at 25 °C
<b>Notes:</b>						
1. Inclusive of initial frequency tolerance at 25°C, variations over supply voltage, load and humidity after 2 times of reflows.						
2. Frequency / temperature characteristics with offset removed.						
IO Characteristics						
Output enable (OE)	V <sub>IH</sub>	0.7×V <sub>DD</sub>	—	—	V	Input high voltage
	V <sub>IL</sub>	—	—	0.3×V <sub>DD</sub>	V	Input low voltage
	R <sub>PUP</sub>	—	50	—	kΩ	Internal pull-up resistor to V <sub>DD</sub>
	T <sub>D</sub>	—	—	3	us	Output disable time, F <sub>CLK</sub> > 10 MHz
	T <sub>E</sub>	—	—	20	us	Output enable time, F <sub>CLK</sub> > 10 MHz

*Continued on next page*

Parameter	Symbol	Min	Typ	Max	Unit	Note
Output Characteristics						
Powerup time	$T_{OSC}$	—	—	4	ms	Time from power reaches $0.9 \times V_{DD}$ to output frequency ( $F_{CLK}$ ) within spec
Duty cycle	DC	45	—	55	%	All formats
Rise/Fall time (20% to 80% VPP)	$T_{R/F}$	—	0.5	1.5	ns	LVC MOS (Load = 10pF // 10k $\Omega$ )
		—	—	350	ps	Differential (100 $\Omega$ termination)
0.8V differential	$V_{OC}$	0.15	0.20	0.25	V	Mid-level
	$V_O$	0.70	0.80	0.90	$V_{PP}$	Swing (Diff)
1.0V differential	$V_{OC}$	0.20	0.25	0.30	V	Mid-level
	$V_O$	0.90	1.00	1.10	$V_{PP}$	Swing (Diff)
1.2V differential	$V_{OC}$	0.25	0.30	0.35	V	Mid-level
	$V_O$	1.10	1.20	1.30	$V_{PP}$	Swing (Diff)
LVC MOS	$V_{OH}$	$0.83 \times V_R$	—	—	V	LVC MOS (Load = 10pF // 10k $\Omega$ )
	$V_{OL}$	—	—	$0.17 \times V_R$	V	
Phase Noise and Jitter						
RMS jitter BW: 12k - 20MHz	$R_J$	—	52	70	fs	$F_{CLK} \geq 100$ MHz
		—	100	200	fs	$F_{CLK} \geq 50$ MHz
		—	150	300	fs	$F_{CLK} < 50$ MHz
Phase noise 156.25MHz 0.8V differential output $V_{DD} = 1.8 - 3.3V$	$PN_{1k}$	—	-137	—	dBc/Hz	Phase noise at 1kHz offset
	$PN_{10k}$	—	-148	—	dBc/Hz	Phase noise at 10kHz offset
	$PN_{100k}$	—	-155	—	dBc/Hz	Phase noise at 100kHz offset
	$PN_{1M}$	—	-162	—	dBc/Hz	Phase noise at 1MHz offset
	$PN_{10M}$	—	-163	—	dBc/Hz	Phase noise at 10MHz offset
PSNR						
Spurs from power noise 50mV ripple $V_{DD} = 1.8V$	PSNR	—	-76	—	dBc	100 kHz sine wave
		—	-75	—	dBc	200 kHz sine wave
		—	-75	—	dBc	500 kHz sine wave
		—	-75	—	dBc	1 MHz sine wave
Spurs from power noise 50mV ripple $V_{DD} = 2.5$ or $3.3V$	PSNR	—	-83	—	dBc	100 kHz sine wave
		—	-83	—	dBc	200 kHz sine wave
		—	-83	—	dBc	500 kHz sine wave
		—	-82	—	dBc	1 MHz sine wave

**Table 2.2. Environmental Compliance and Package Information**

Parameter	Value
Moisture sensitivity level (MSL)	3

**Notes:**  
For additional product information not listed in the data sheet (e.g. RoHS Certifications, MSDS data, qualification data, REACH Declarations, ECCN codes, etc.), contact [aeonsemi.com/contact\\_us](http://aeonsemi.com/contact_us)

**Table 2.3. Absolute Maximum Ratings<sup>1</sup>**

Parameter	Symbol	Rating	Unit
Maximum operating temperature	$T_{AMAX}$	125	°C
Storage temperature	$T_S$	-55 - 125	°C
Supply voltage	$V_{DD,MAX}$	-0.5 - 3.8	V
Input voltage	$V_{IN,MAX}$	-0.5 - $V_{DD}+0.3$	V
ESD HBM (JESD22-A114)	HBM	4.0	kV
ESD CDM (JESD22-C101)	CDM	1.0	kV
Solder Temperature <sup>2</sup>	$T_{PEAK}$	260	°C
Solder time at $T_{PEAK}$ <sup>2</sup>	$T_P$	20 - 40	sec

**Notes:**

- Stresses beyond those listed in this table may cause permanent damage to the device. Functional operation specification compliance is not implied at these conditions. Exposure to maximum rating conditions for extended periods may affect device reliability.
- The device is compliant with JEDEC J-STD-020.

### 3. Recommended Output Terminations

#### 3.1. Differential Output

The output drivers support AC-coupled or DC-coupled terminations as shown in figures below.

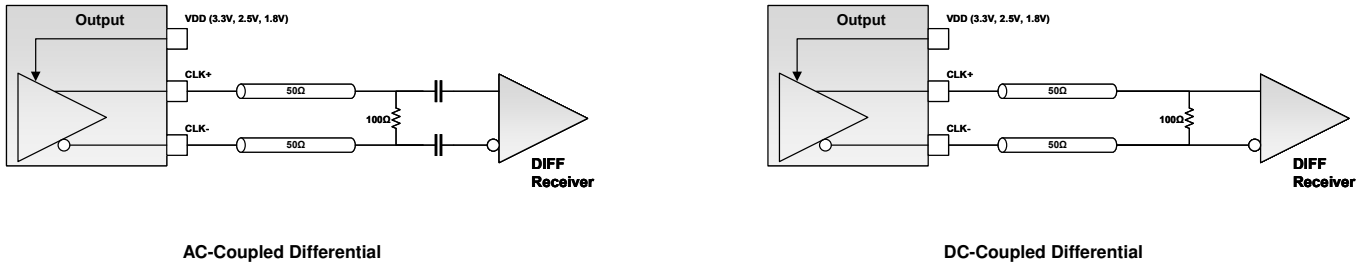

Figure 3.1. Differential Output Terminations

#### 3.2. CMOS Output

Dual CMOS output format options support either complementary or in-phase signals for two identical frequency outputs. This feature enables replacement of multiple XOs with a single AS5221 device.



Figure 3.2. Integrated 1:2 CMOS Buffer Supports In-Phase or Complementary Outputs

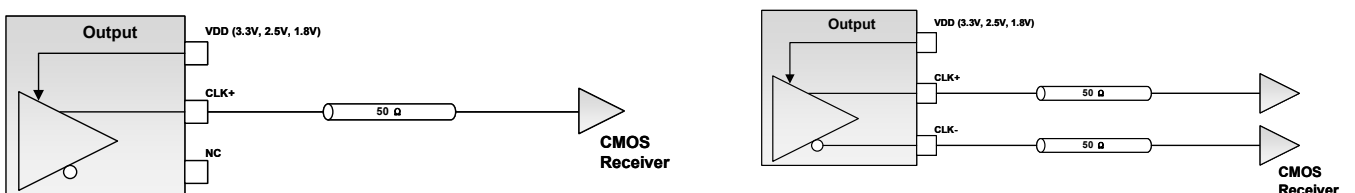

Figure 3.3. LVCMOS Output Terminations

4. Package Outline Drawing

Figure 4.1. shows the package outline drawing for the AS5221 devices. Details of dimension for different size options are listed in Table 4.1.

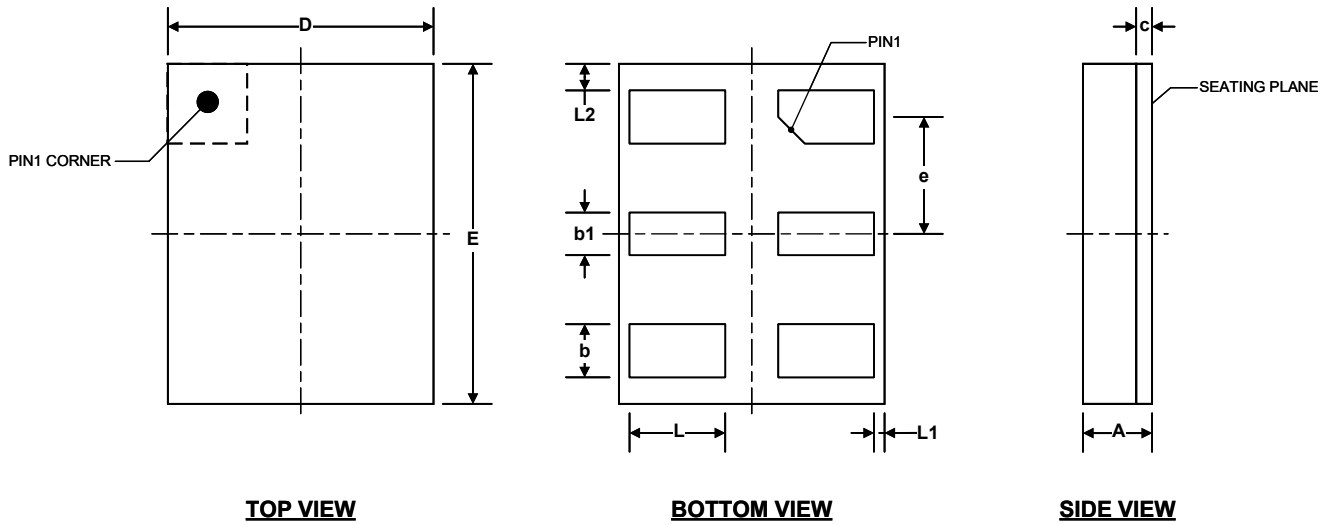

Figure 4.1. Package Outline Drawing

Table 4.1. Dimensions of Package Outline Drawing (mm)

Symbol	Min	Nom	Max
A	0.790	0.890	0.990
b	0.225	0.300	0.375
b1	0.225	0.300	0.375
D	1.550	1.600	1.650
e	—	0.750 BSC	—
E	1.950	2.000	2.050
L	0.375	0.450	0.525
L1	0.025	0.100	0.175

## 5. Recommended PCB Land Pattern

Figure 5.1. shows the drawing of recommended PCB land pattern for the AS5221 devices. Details of dimension for different size options are listed in Table 5.1.

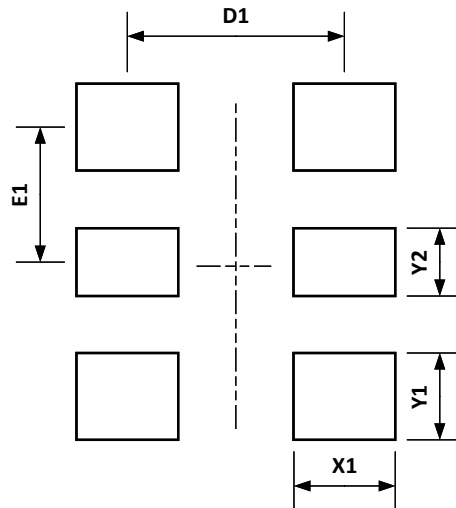

Figure 5.1. Recommended PCB Land Pattern

Table 5.1. Dimensions of Recommended PCB Land Pattern (mm)

Symbol	2016 Package
D1	1.05
E1	0.75
X1	0.75
Y1	0.50
Y2	0.50

### Notes:

The following notes and stencil design are shared as recommendations only. A customer or user may find it necessary to use different parameters and fine-tune their SMT process as required for their application and tooling.

### General

1. All dimensions shown are in millimeters (mm) unless otherwise noted.
2. Dimensioning and Tolerancing is per the ANSI Y14.5M-1994 specification.
3. This Land Pattern Design is based on the IPC-7351 guidelines.
4. All dimensions shown are at Maximum Material Condition (MMC). Least Material Condition (LMC) is calculated based on a Fabrication Allowance of 0.05 mm.

### Solder Mask Design

1. All metal pads are to be non-solder mask defined (NSMD). Clearance between the solder mask and the metal pad is to be 60  $\mu$ m minimum, all the way around the pad.

### Stencil Design

1. A stainless steel, laser-cut and electro-polished stencil with trapezoidal walls should be used to assure good solder paste release.
2. The stencil thickness should be 0.125 mm (5 mils).
3. The ratio of stencil aperture to land pad size should be 0.8 1 for the pads.

### Card Assembly

1. A No-Clean, Type-3 solder paste is recommended.
2. The recommended card reflow profile is per the JEDEC/IPC J-STD-020 specification for Small Body Components.

6. Top Mark

Figure 6.1. shows the top mark specifications for the AS5221 devices. Description of each line is listed in Table 6.1.

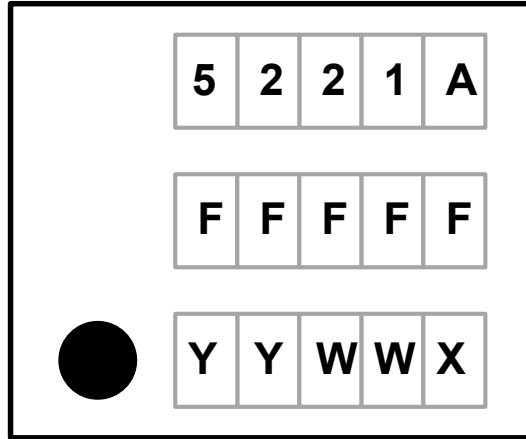

Figure 6.1. Top Mark

Table 6.1. Top Mark Description

Line	Position	Description
1	1-6	Device Name
2	1-5	Unique 5-digit Device Configuration Number
3	1	Pin 1 orientation mark (dot)
	2-3	Year (last two digits of the year), to be assigned by assembly site (ex: 2025 = 25)
	4-5	Calendar Work Week number (1-53), to be assigned by assembly site
	6	Manufacturer code

## 7. Important Notice and Disclaimer

Aeonsemi provides technical information such as datasheets, characterization reports, application notes, reference designs, and other resources “as is” and with all faults, and disclaims all warranties, express and implied, including without limitation any implied warranties of merchantability, fitness for a particular purpose or non-infringement of third-party intellectual property rights. These resources are subject to change without notice except when PCN is applicable. Aeonsemi grants you permission to use these resources only for development of an application that uses the Aeonsemi products described in the resource. Other reproduction and display of these resources are prohibited. No license is granted to any other Aeonsemi intellectual property right or to any third-party intellectual property right. Aeonsemi disclaims responsibility for, and you will fully indemnify Aeonsemi and its representatives against, any claims, damages, costs, losses, and liabilities arising out of your use of these resources.

Aeonsemi’s products are provided subject to Aeonsemi’s Terms of Sale ([aeonsemi.com/terms](https://aeonsemi.com/terms)) or other applicable terms available either on [aeonsemi.com](https://aeonsemi.com) or provided in conjunction with such Aeonsemi products.

Contact: [marketing@aeonsemi.com](mailto:marketing@aeonsemi.com)

## 8. Revision History

Revision	Date	Description
1.03	Mar 2026	Updated the Top Mark Rule
1.02	Sep 2025	Corrected several description errors
1.01	Aug 2025	Officially release as mass production version
0.09	Feb 2025	Added "2016" package outline diagram
0.08	Aug 2024	Updated several items
0.07	Apr 2024	Remove the package outline drawings temporarily
0.06	Feb 2024	Updated the "Ordering guide"
0.05	Aug 2023	Revised the stability for D-grade option
0.04	Jul 2023	Updated the package outline
0.03	Jun 2023	Updated the "Ordering guide" and added phase noise jitter for clock $\geq 100$ MHz
0.02	Feb 2023	Updated the "Temperature Stability Grade" D grade
0.01	Nov 2021	Preliminary release